

ZeroPlay® Miter Bar System User Manual

For creating precision shop-built sleds and jigs.

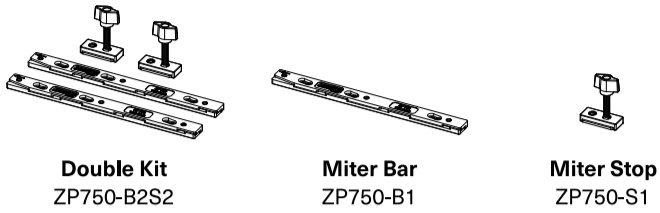

WARNING
Always wear safety glasses and hearing protection. Follow all safety precautions and use best practices. Microjig assumes no liability for any products not sold and manufactured by Microjig.

Instructions

Make sure that your table saw is properly tuned and maintained before using the ZeroPlay™ System. It is important that the rip fence is exactly parallel with the blade. Perform all steps as accurately as possible.

Miter Bar adjusts from 0.72" to 0.78" (18.3mm–19.8mm) wide. Push the bottom bar away from the top bar to decrease width [Fig 1a]. Push the bars together to widen [Fig 1b].

Step 1 – Assemble Hardware

- Stack the Top Bar (B) on top of the Bottom Bar (A). The arrows should be facing upwards and in the same direction.
- Insert (3x) button head screws (C) through the counterbored slots in the Top Bar as shown below. Loosely secure both bars together using the hex key (D).
- Adjust the bars to the narrowest setting [Fig 1a] and lightly tighten the screws.

Miter Stop only

- Insert the nylon set screw (M) into the brass insert of the Miter Stop (H) with a small flathead screwdriver.

Parts List

#	Miter Bar Parts	Qty	Part #
A	Bottom Bar (with wedges)	1	ZP750-P1
B	Top Bar (with logo)	1	ZP750-P2
C	#8-32 x 3/16" button head screw	3	ZP-H1-EH
D	3/32" hex key	1	ZP-H2-EH
E	#8-32 x 1/2" pan head screw	3	ZP-H3-EH
F	#10 flat washer	3	ZP-H4-EH
G	#8-32 x 3/4" pan head screw	3	ZP750-H19-EH

#	Miter Stop Parts	Qty	Part #
H	Miter Stop	1	ZP750-P3
I	1/4"-20 x 1-3/4" T-bolt	1	GR-H12-EH
J	1/4"-20 yellow wing knob	1	ZP-H6
K	5/16" OD O-ring	1	ZP-H7
L	1/4" x 1/2" flat washer	1	ZP-H8-EH
M	Nylon 1/4"-20 x 1/4" set screw	1	ZP-H9

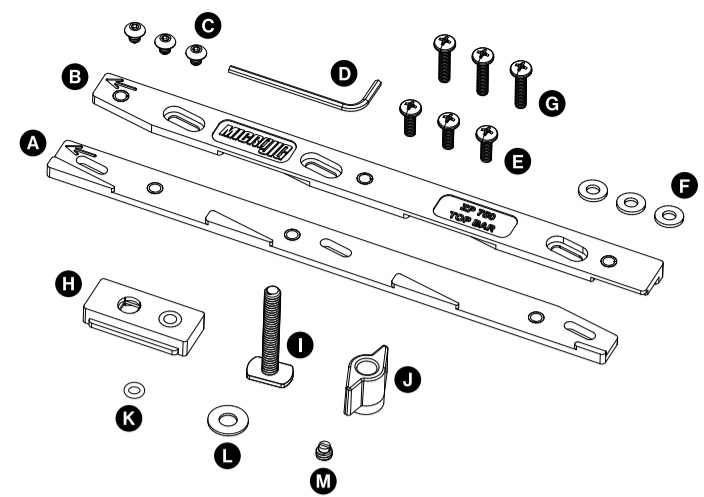

Required Tools (Not included)

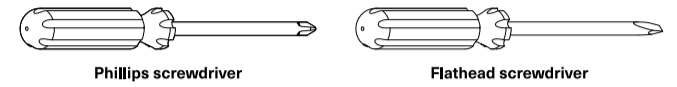

Compatibility

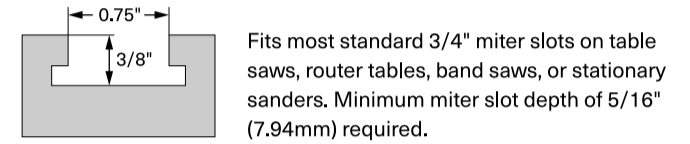

Miter Bar compatible miter slot types

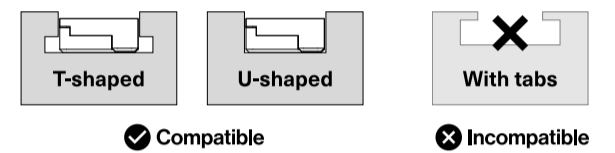

Miter Stop compatible miter slot types

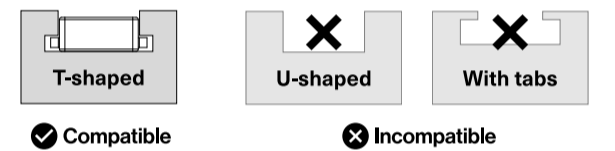

Step 2 – Mark & Drill Sled Base

Layout ZeroPlay® holes and other sled features before drilling or cutting.

- Draw a center line where the Miter Bar will be mounted to the sled.
- Mark a point for the first mounting hole ($\geq 1"$ from the top edge) and label it M1 (closest to the arrows). Mark two more mounting holes 4" (101.6mm) apart and label them M2 and M3 [Fig 2a].
- Starting from M1, mark three adjustment holes 1-1/16" (27mm), 3-5/16" (84.1mm), and 7-5/16" (185.7mm) backwards along the center line. Label them A1, A2, and A3 [Fig 2b].
- Drill 3/4" (19mm) through holes at A1, A2 and A3.
- Drill 1/2" (12mm) diameter counterbores 5/16" (8mm) deep at M1, M2, and M3. Then drill 1/4" (6mm) through holes at each mounting hole (M1, M2, M3) through the center of the counter bore [Fig 2c].

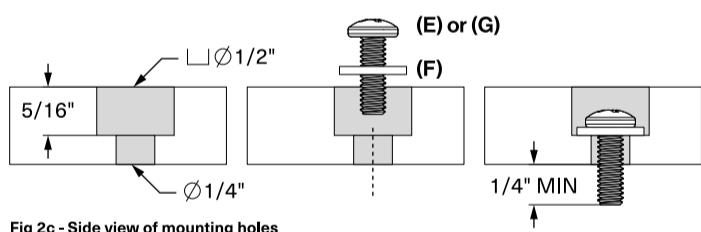

Fig 2c - Side view of mounting holes

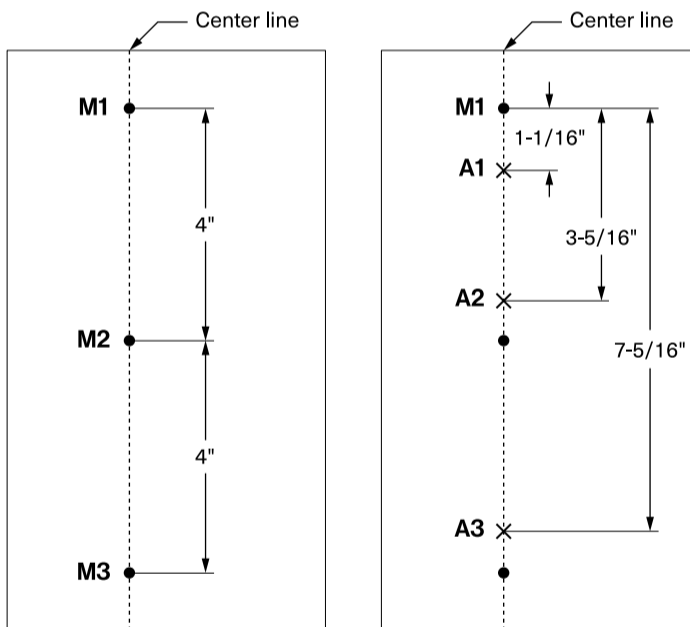

Fig 2a - Mounting hole locations

Fig 2b - Adjustment hole locations

Step 3 – Mount Miter Bar

- Using a philips screwdriver, attach the Miter Bar to the bottom of the sled using either:
 - For 1/2" thick sled bases: (3x) 1/2" pan head screws (E) OR
 - For 3/4" thick sled bases: (3x) 3/4" pan head screws (G)
 Insert the pan head screws with flat washers (F) through each mounting hole (M1, M2, M3) and tighten [Fig 3a].
- Each adjustment slot should be visible through the adjustment holes (A1, A2, A3) drilled in Step 2.4.
- Place the sled base on top of your table saw surface so the Miter Bar is set into one of the miter slots. Push the sled to the right so the Miter Bar is firmly against the inner wall of the miter slot [Fig 3b].
- Using the hex key (D), loosen the 3 button head screws in the Miter Bar through the adjustment holes [Fig 3c].

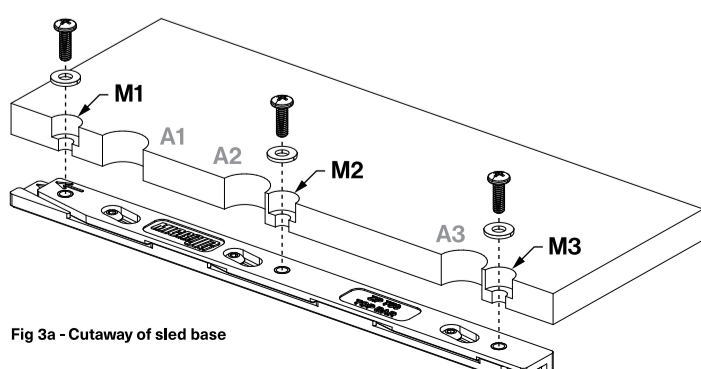

Fig 3a - Cutaway of sled base

- Use the hex key to gently slide one of the button head screws downwards so the Miter Bar expands to completely fill the miter slot. Then, tighten each button head screw [Fig 3d].
- Test the Miter Bar fit by sliding the sled along the miter slot. It should slide freely with no side-to-side play. Repeat the previous steps if the fit is too tight or too loose.

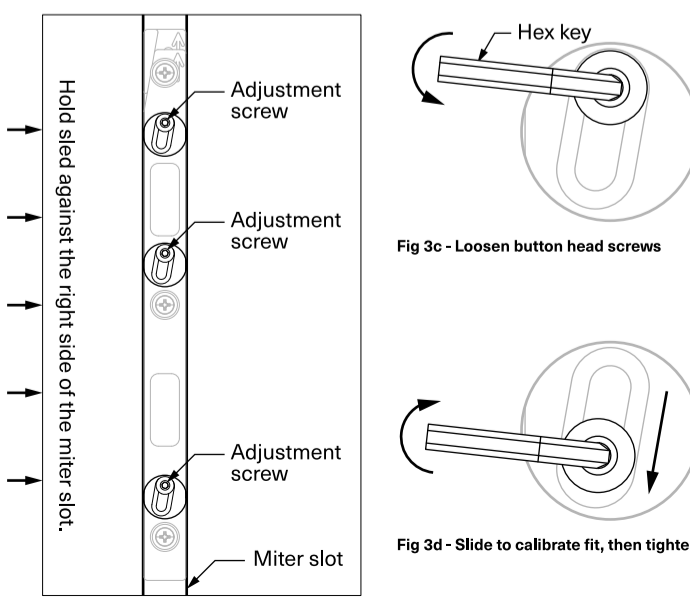

Fig 3b - Top view of assembled sled

Fig 3c - Loosen button head screws

Fig 3d - Slide to calibrate fit, then tighten

Step 4 – Square sled

- Move the rip fence so it touches the side of your sled base and lock the fence in place. The fence position should be close to or slightly past the saw blade [Fig 4a].
- Partially loosen the three mounting screws and push the sled base firmly against the rip fence. Make sure the sled is square (90°) to the rip fence and retighten each mounting screw [Fig 4b–4d].
- If the sled base is set slightly past the saw blade, cut the edge to create a zero-clearance fit.

TIP: Use two ZeroPlay™ Miter Bars inline (one in front of the other) for deep projects like panel cutting sleds, or in parallel (one in each miter slot) for wider bases like crosscut sleds.

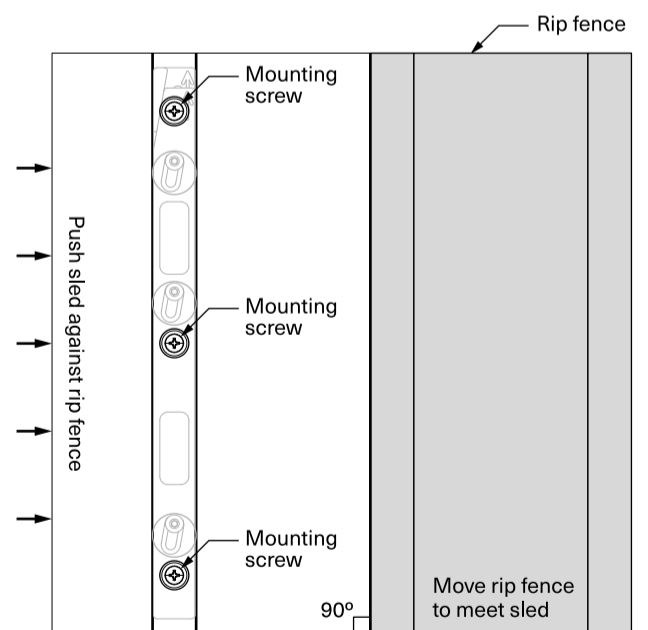

Fig 4a - Top view of sled and rip fence

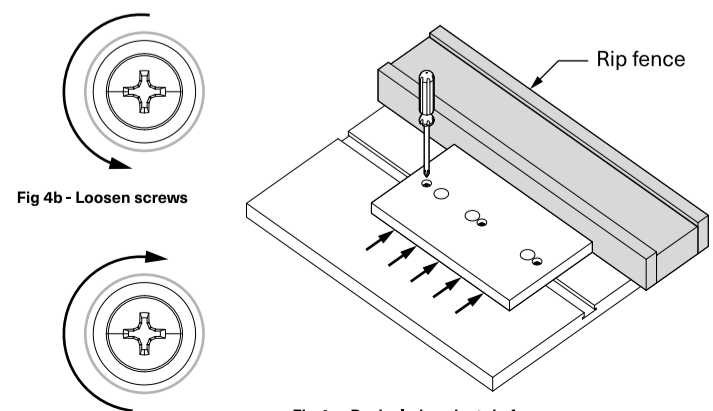
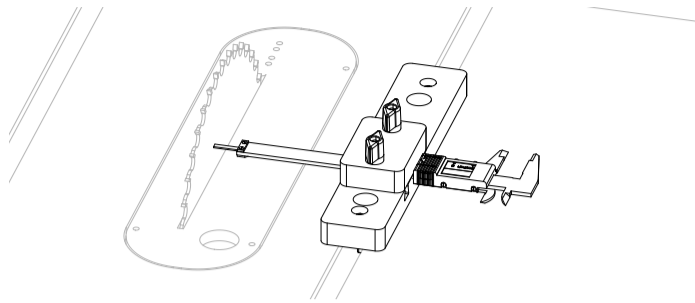

Fig 4b - Loosen screws

Fig 4d - Tighten screws

ZeroPlay® Miter Bar Saw Setup Jig Plans

For setting and fine tuning your miter slot, saw blade, and rip fence



WARNING

Always wear safety glasses and hearing protection. Follow all safety precautions and use best practices. Microjig assumes no liability for any products not sold and manufactured by Microjig.

Instructions

Step 1 – Mark and drill holes

- 1.1 Draw a centerline down the 10" length of the Jig Base and mark it at 1" (25mm) and 9" (228mm) from the front edge. These will be the mounting holes M1 and M2. [Fig 1a].
NOTE: the center mounting hole is not used.
- 1.2 Make three more marks along this line at 2-1/16", 4-5/16" and 8-5/16" (52mm, 110mm and 211mm) from the front. These will be the adjustment holes A1, A2, and A3 [Fig 1a].
- 1.3 Drill 1/2" (12mm) diameter counter bore holes, 5/16" (8mm) deep at M1 and M2 [Fig 1b].
- 1.4 Drill 1/4" (6mm) diameter holes through the center of the counter bores cut in the previous step [Fig 1b].
- 1.5 Drill 3/4" (19mm) diameter holes through the Jig Base at A1, A2, and A3 [Fig 1b].
- 1.6 Draw a center line along the 3" (76mm) length of the Clamp Plate and mark it 1/2" (13mm) in from each end [Fig 1c].
- 1.7 Drill 1/4" (6mm) through holes at these points. Ease the corners of the jig base and clamp plate if desired.

Parts List

#	Saw Setup Jig Parts	Qty
A	Jig Base: 10" x 2" x 3/4" (250mm x 50mm x 18mm)	1
B	Clamp Plate: 3" x 2" x 3/4" (76mm x 50 x 18mm)	1
C	ZeroPlay™ Guide Bar	1
D	1.5" MatchFit™ Track Screws with wing knobs	2
E	360 Sled Kit (substitute for parts C + D)	1

Wood types: void-free plywood (e.g. Baltic birch), standard MDF, or seasoned solid wood.

Required Tools (Not included)

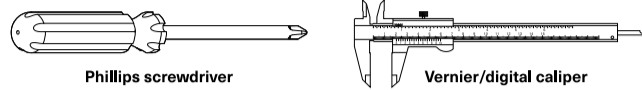

To be safe and accurate, your saw must be set up correctly and as precisely as possible. This simple jig helps you set and fine tune your saw to get the best possible cuts from it.

The jig holds a digital or vernier caliper as it slides up and down the miter slot so you can measure the exact set up of your saw table and rip fence.

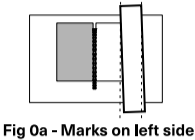
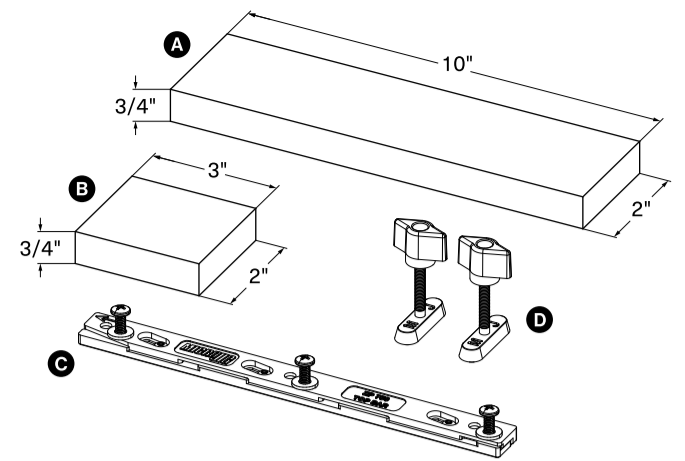

Fig 0a - Marks on left side

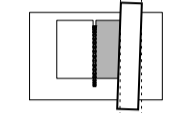

Fig 0b - Marks on right side

Tool marks or burning on ripped faces

Excess tool marks or burning on ripped faces means the fence is not parallel to the blade.

Marks are on the left side of the cut means the back of the fence is too far right [Fig 0a].

Marks are on the right side of the cut means the back of the fence is too far left [Fig 0b].

Step 2 – Cut Dovetail Tracks and dado on Jig Base

- 2.1 Mark the Jig Base 5-1/4" and 7-1/4" (70mm and 121mm) from the front edge. These are the Dovetail Track locations [Fig 2a].
- 2.2 Refer to the instructions included with the Dovetail Screws and cut Dovetail Tracks across the Jig Base centered on the lines [Fig 2c].
- 2.3 Mark the Jig Base 6-1/4" from the rear edge. Cut a dado at this line the same width as, and slightly shallower than, your caliper. [Fig 2c].

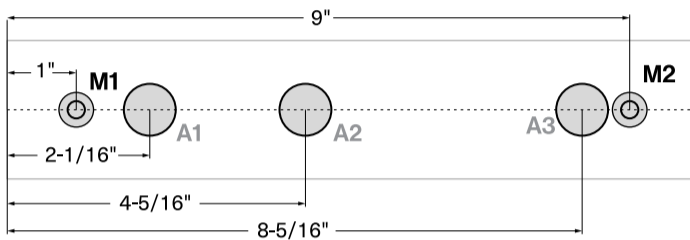

Fig 1a - Top view of Jig Base



Fig 1b - Section view of side of Jig Base

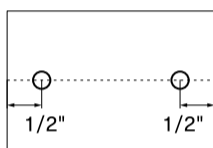

Fig 1c - Top view of Clamp Plate

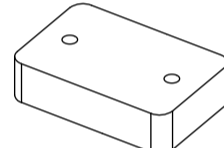

Fig 1d - Finished Clamp Plate

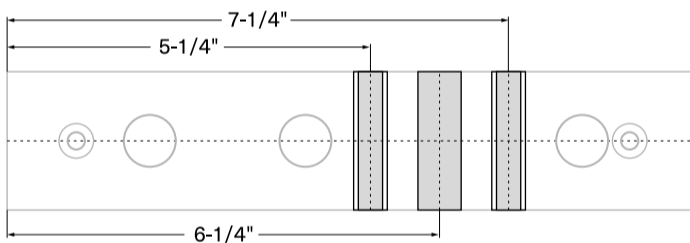

Fig 2a - Dovetail Track and dado locations

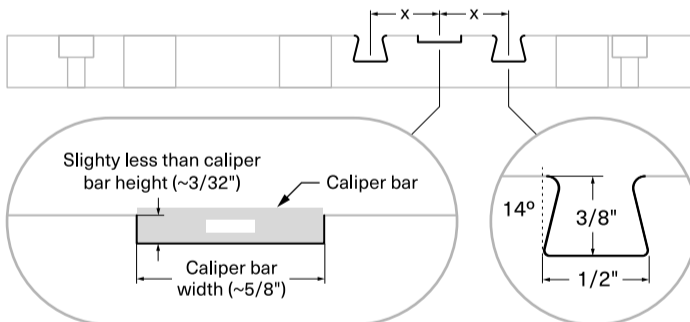

Fig 2c - Dado and Dovetail Track dimensions

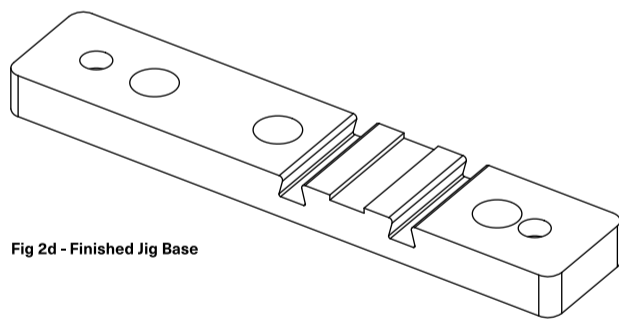

Fig 2d - Finished Jig Base

Step 3 – Mount and square jig

Refer to Steps 3-4 of the Miter Bar user manual.

NOTE: This jig has only two mounting screws rather than three. The center mounting hole of the Miter Bar is not used.

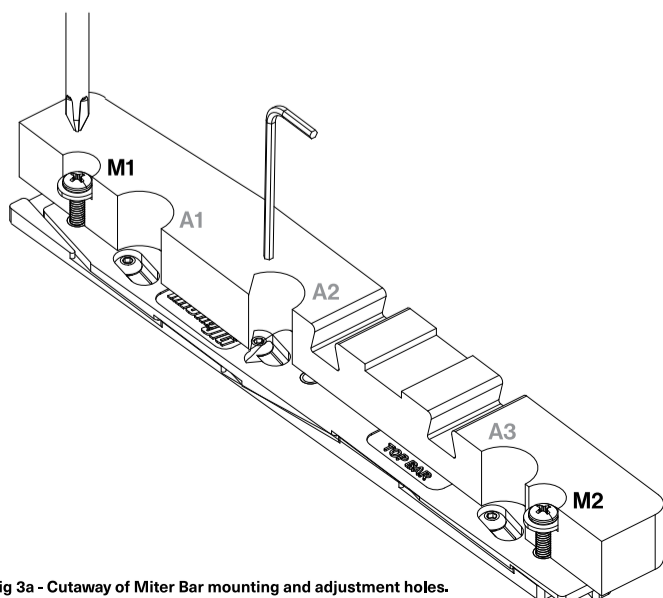

Fig 3a - Cutaway of Miter Bar mounting and adjustment holes.

Step 4 – Mount caliper

- 4.1 Slide a Dovetail Screw into each Dovetail Track in the Jig Base.
- 4.2 Set the caliper bar into the dado in the Jig Base. Position it with the depth rod towards the blade (it can be reversed as needed).
- 4.3 Slide the Clamp Plate over the screws so it rests on the caliper bar.
- 4.4 Use the knobs to loosely secure the caliper bar in place.

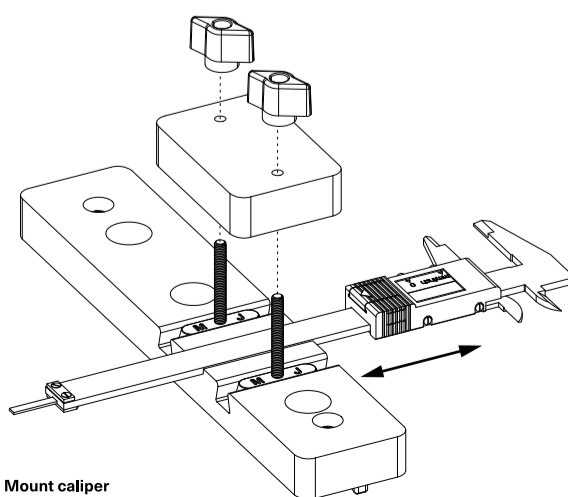

Fig 4a - Mount caliper

Step 5 – Adjust miter slot

- 5.1 Unplug the saw and raise the blade to full height. Mark the blade at the closest point to the front of the table [Fig 5a].
- 5.2 Adjust the caliper depth stop to touch the blade body (not the tooth) at this mark. Zero the caliper display [Fig 5b].
- 5.3 Rotate the blade until the mark is as far to the rear as possible. Slide the jig back along the miter slot and re-measure the distance to the mark. Both measurements should be the same [Fig 5c-5e].
- 5.4 If there is a difference front to back, adjust the miter slot so it is parallel to the blade. (refer to your saw's user manual).

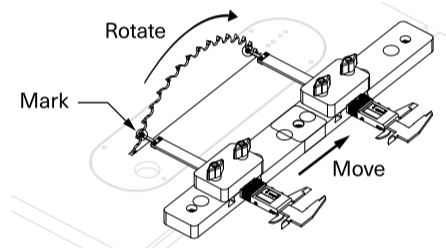

Fig 5a - Adjust miter slot

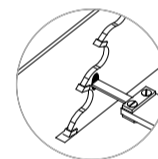

Fig 5b - Measure 1

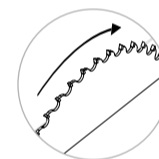

Fig 5c - Rotate blade

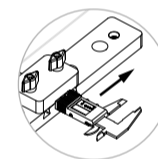

Fig 5d - Move jig

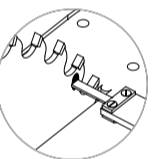

Fig 5e - Measure 2

Step 6 – Adjust rip fence

- 6.1 Flip the caliper so that the depth rod is toward the rip fence [Fig 6a].
- 6.2 Slide the jig as far forward as possible and measure the distance to the rip fence. Make sure the Miter Bar is fully engaged inside the miter slot. Zero the display on the caliper [Fig 6b].
- 6.3 Slide the jig as far backward as possible and measure the distance to the rip fence. Both measurements should be the same [Fig 6b].
- 6.4 If there is a difference front to back, adjust the rip fence so it is parallel to the miter slot. (refer to your saw's user manual).

NOTE: Not all rip fence faces are perfectly uniform from end to end. Check several points along the length of the rip fence to find any high spots. Measure at the highest spot both front and back.

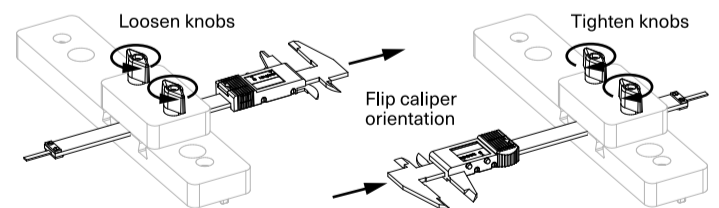

Fig 6a - Face caliper depth rod towards rip fence

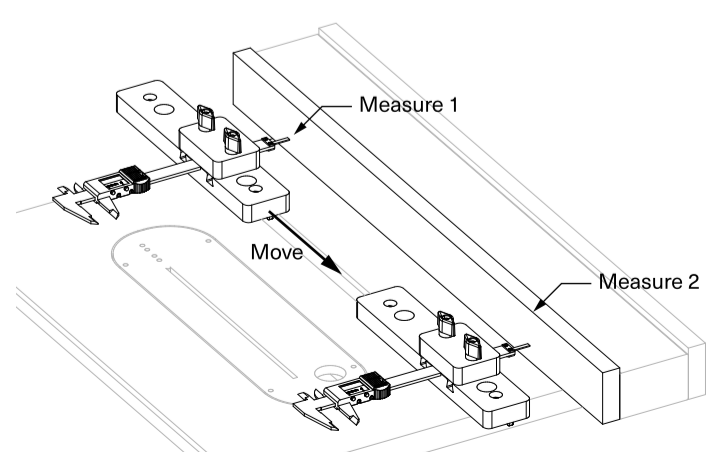

Fig 6b - Measure rip fence face